

## Entraînement direct

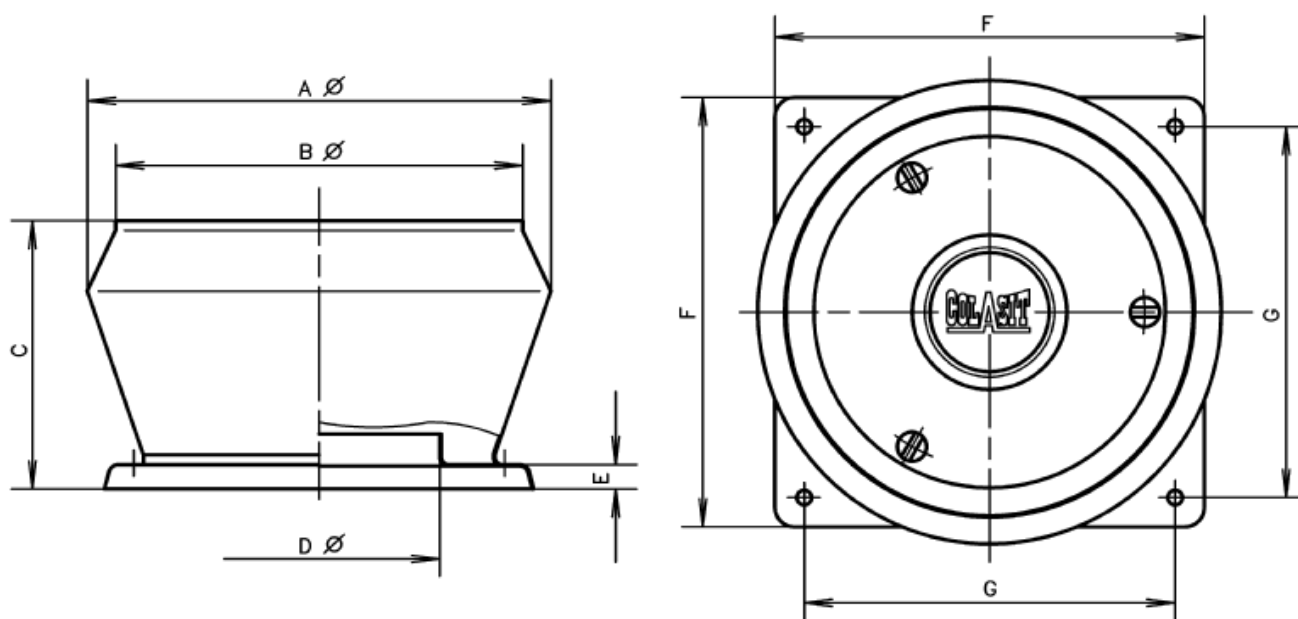

CDVA	400	450	500	560	630	710
A Ø	782	782	944	944	1154	1154
B Ø	700	700	835	835	980	980
C	440	440	530	530	620	620
D Ø	402	452	503	562	633	713
E	50	50	50	50	50	50
F	740	740	877	877	1070	1070
G	620	620	760	760	940	940