

Entraînement direct

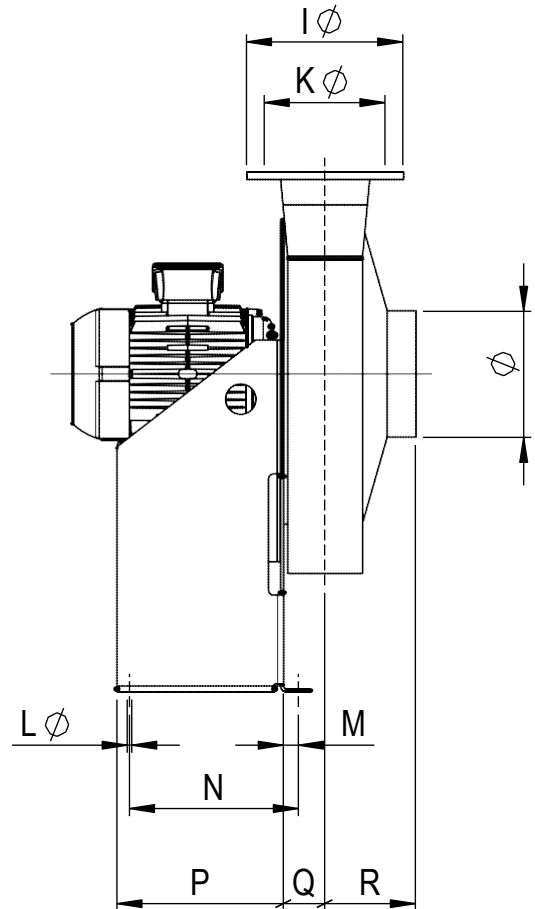

CHVS	63	90	125	160	200	250
A	309	317	327	338	351	361
B	275	281	289	298	307	318
C	311	323	339	356	375	395
D	307	311	315	320	327	327
E	630	630	630	630	630	630
F	400	400	400	400	400	400
G	545	545	545	545	545	545
H	619	619	619	619	619	619
I Ø	120	150	185	220	260	310
K Ø	63	90	125	160	200	250
L Ø	9	9	9	9	9	9
M	30	30	30	30	30	30
N	335	335	335	335	335	335
P	330	330	330	330	330	330
Q	61	64	67.5	71.5	75.5	82
R	180	180	180	180	180	180

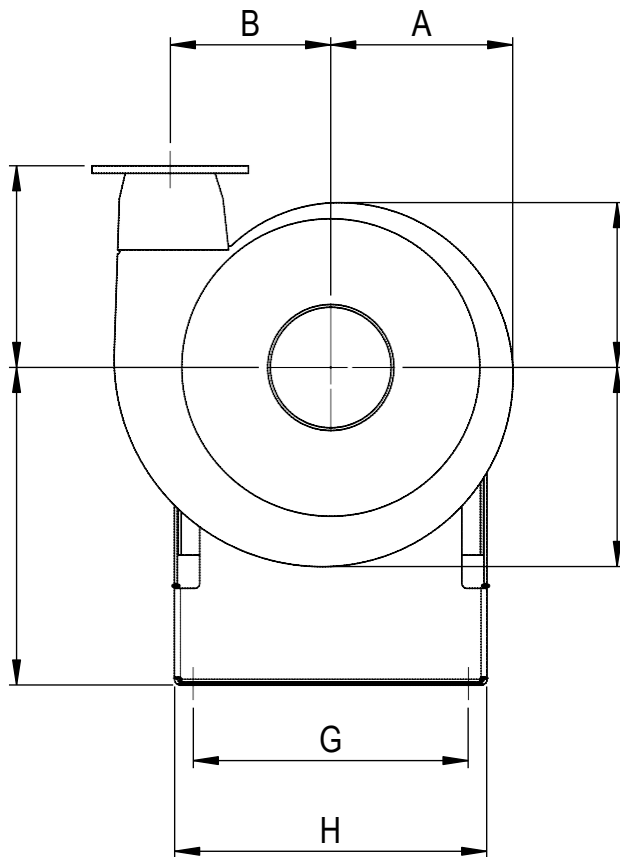
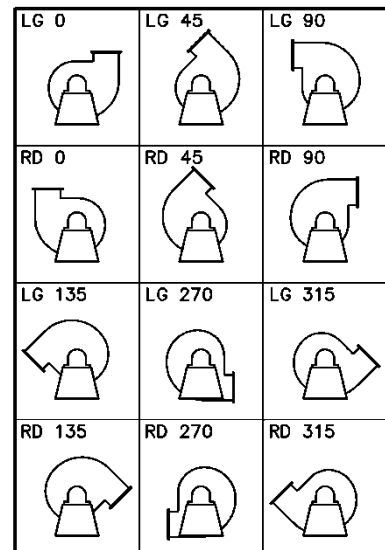

Entraînement à courroie

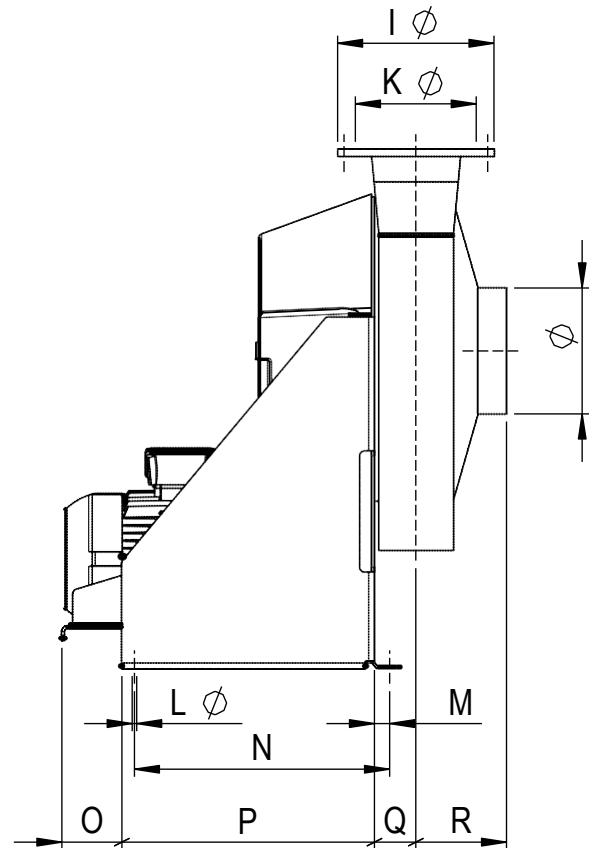
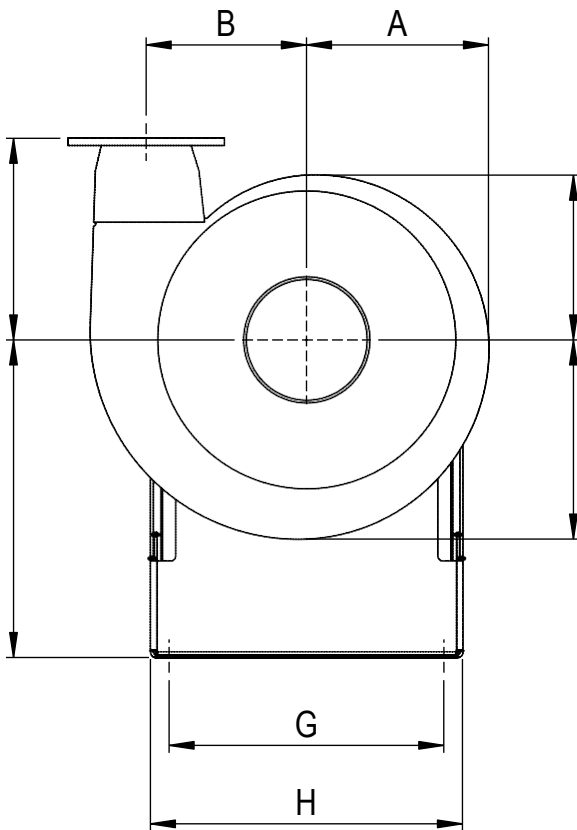

CHVS	63	90	125	160	200	250
A	309	317	327	338	351	361
B	275	281	289	298	307	318
C	311	323	339	356	375	395
D	307	311	315	320	327	327
E	630	630	630	630	630	630
F	400	400	400	400	400	400
G	545	545	545	545	545	545
H	619	619	619	619	619	619
I Ø	120	150	185	220	260	310
K	63	90	125	160	200	250
L	9	9	9	9	9	9
M	30	30	30	30	30	30
N	506	506	506	506	506	506
O	119	119	119	119	119	119
P	501	501	501	501	501	501
Q	61	64	67.5	71.5	75.5	82

