

Exhaust air purification

**CRVE**

Counter-flow exhaust air scrubber  
made of plastic

Setting the standard for clean air. Worldwide.

**COLASIT**

The Colasit CRVE counter-flow exhaust air scrubber with a vertical design cleans acidic and alkaline contamination from highly-contaminated process air up to a volume of 60 000 m<sup>3</sup>/h. Special versions with higher air performance are available on request.

## Utilization

Cleaning highly-contaminated process air with acidic or alkaline contamination.

For use in:

- Food industry
- pharmaceutical, chemical or biochemical industry
- Semiconductor, solar power, and surface technology
- Sewage and waste management systems
- Composting
- Drying processes

## Characteristics

### Volume flow

min. 700 m<sup>3</sup>/h to max. 60000 m<sup>3</sup>/h

### Operating pressure

+/- 1500 Pa (special models for higher pressures available)

### Efficiency (total mechanical)

max. 99.9%

### Operating temperature

max. 40°C (special models for higher temperatures available)

## Operating principle

A scrubbing liquid is injected into the vertical exhaust air flow in the circuit. Water-soluble impurities are scrubbed out through the addition of acids or alkalis. A collecting container gathers hazardous substances.

## Design

Custom-designed to your specifications

## Construction

Made of non-corrosive plastics: **PP, PPs, PE, PVC, PVDF, GRP**. Packaging materials ensure sufficient boundary surface area between the gas and fluid phase. A mist eliminator is used to separate liquid drops that have been carried along.

## Ex protection

- Available in ATEX model for **Zone 1/2** 

## Accessories

- pH measurement, conductivity measurement
- Chemical dosing, dosing tank
- Automatic sludge removal from the washing fluid
- Designed for outdoor installation, screw-in heater
- Inclined bottom
- Redundant scrubber pump
- Aerosol separator
- Alternative packaging material
- Splash guard
- Process control
- Containment basin

## Energy recovery

The energy of the exhaust air and exhaust gas can be re-used. This is accomplished via a plastic heat exchangers, whereby the thermal energy is used directly in the exhaust air scrubber or separately.

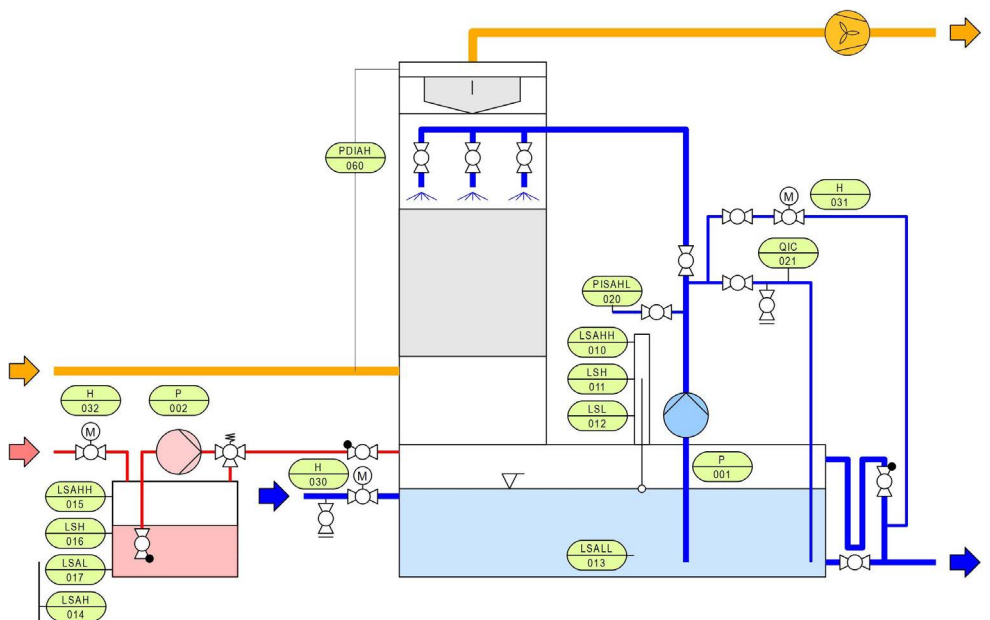

## Exhaust air purification from Colasit

The exhaust air and exhaust gas from industrial applications, laboratories, and building technology can be hazardous to health and the environment. Colasit has been supporting you for many decades by supplying professional exhaust air purification systems to protect employees and the environment from harmful substances and odor emissions.

## Key features

Colasit's exhaust air purification systems made of plastic are designed specifically for the processes they will be used in. Thanks to our wide range of exhaust air scrubbers in horizontal and vertical models, we can handle nearly any application.

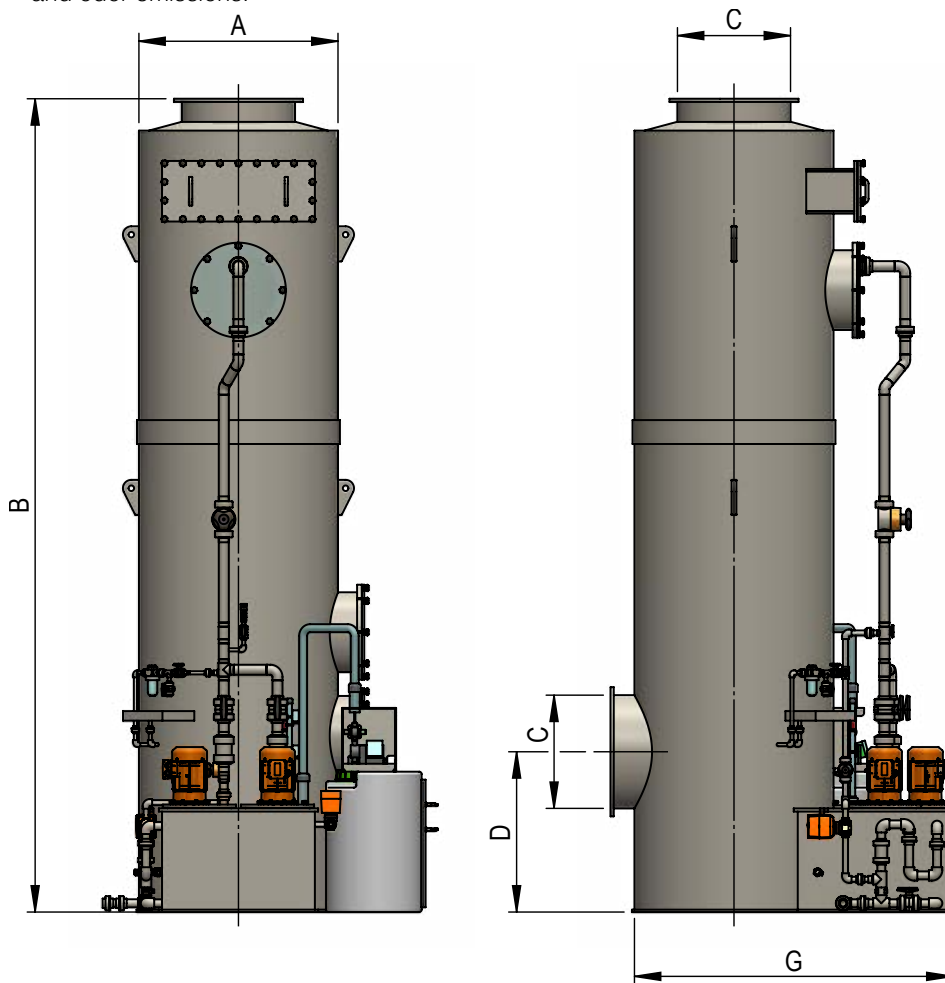

The Colasit REYCLAIR exhaust air scrubbers CRVE are available in the following standard sizes:

	A	B	C	D	E	F	G	Volume flow
<b>CRVE 400</b>	400 mm	4700 mm	225 mm	825 mm	4535 mm	350 mm	1000 mm	700 – 1200 m <sup>3</sup> /h
<b>CRVE 500</b>	500 mm	4700 mm	280 mm	850 mm	4510 mm	400 mm	1000 mm	1100 – 1800 m <sup>3</sup> /h
<b>CRVE 630</b>	630 mm	4900 mm	355 mm	890 mm	4670 mm	465 mm	1300 mm	1700 – 2900 m <sup>3</sup> /h
<b>CRVE 710</b>	710 mm	4900 mm	400 mm	910 mm	4650 mm	505 mm	1300 mm	2200 – 3600 m <sup>3</sup> /h
<b>CRVE 900</b>	900 mm	5200 mm	500 mm	960 mm	4900 mm	600 mm	1500 mm	3500 – 5800 m <sup>3</sup> /h
<b>CRVE 1000</b>	1120 mm	5200 mm	560 mm	990 mm	4870 mm	710 mm	1500 mm	4300 – 7100 m <sup>3</sup> /h
<b>CRVE 1250</b>	1250 mm	5400 mm	710 mm	1065 mm	4995 mm	775 mm	1850 mm	6700 – 11100 m <sup>3</sup> /h
<b>CRVE 1500</b>	1500 mm	5400 mm	900 mm	1160 mm	4900 mm	900 mm	2100 mm	9600 – 16000 m <sup>3</sup> /h
<b>CRVE 1750</b>	1750 mm	5600 mm	1000 mm	1210 mm	5050 mm	1025 mm	2350 mm	13000 – 21700 m <sup>3</sup> /h
<b>CRVE 2000</b>	2000 mm	6000 mm	1120 mm	1270 mm	5390 mm	1150 mm	2600 mm	17000 – 28300 m <sup>3</sup> /h
<b>CRVE 2250</b>	2250 mm	6000 mm	1250 mm	1335 mm	5325 mm	1275 mm	2850 mm	21500 – 35800 m <sup>3</sup> /h
<b>CRVE 2500</b>	2500 mm	6000 mm	1250 mm	1335 mm	5325 mm	1400 mm	3100 mm	26600 – 44200 m <sup>3</sup> /h
<b>CRVE 2750</b>	2750 mm	6500 mm	1500 mm	1460 mm	5700 mm	1525 mm	3350 mm	32100 – 53500 m <sup>3</sup> /h
<b>CRVE 3000</b>	3000 mm	6500 mm	1500 mm	1460 mm	5700 mm	1650 mm	3600 mm	38200 – 63700 m <sup>3</sup> /h

# Worldwide

Colasit is a worldwide leading provider of chemically resistant fans, exhaust air purification systems, ventilation systems for corrosive and environmentally harmful exhaust air and gases as well as apparatus and processing systems for chemically aggressive liquid media.



Exhaust air purification systems made of plastic for treating environmentally hazardous exhaust air and gases



Plastic fans for efficient and safe conveying of corrosive exhaust air and gases



Ventilation systems made of plastic for efficient routing of corrosive exhaust air and gases



Processing systems, containers, vessels, and equipment for safe handling of chemically aggressive liquid media



Installation, repair, and replacement parts services

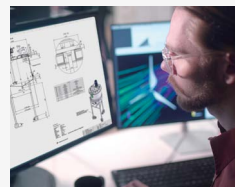

Consultation and engineering services in plastic construction for individual components to entire systems

## COLASIT AG

Plastic construction • Faulenbachweg 63 • 3700 Spiez, Switzerland  
Phone +41 (0)33 655 61 61 • ventilations@colasit.com

[www.colasit.com](http://www.colasit.com)

Competence in plastics. Worldwide.

